



WWW.MORETRACTION.COM



VPS

**VEHICLE POSITION
SENSOR**

COPYRIGHT NOTICE

**Copyright © 1999-2019 Davis Technologies, LLC.
All rights reserved.**

Information in this document is subject to change without notice. Other products and companies referred to herein are trademarks or registered trademarks of their respective companies or mark holders. Any components shown are for illustration or instructional purposes only.

Publication and redistribution of this manual over the Internet or in any other medium without prior written content is expressly forbidden. In all cases this copyright notice must remain intact and unchanged.

Davis Technologies, LLC.

PO Box 8250

Asheville, NC. 28814

(828) 645-1505

email: support@moretraction.com

web: www.MORETRACTION.com

TRADEMARKS

All trademarks used herein are the property of their respective owners.

03/19

TABLE OF CONTENTS

TABLE OF CONTENTS	2
INTRODUCTION.....	5
REMOTE DISPLAY.....	7
VIRTUAL TIME SLIP	8
OPTIONAL CONTROL STRATEGIES	9
WHEELIE CONTROL (add-on purchased separately)	9
TRACTION CONTROL (add-on purchased separately)	10
DIGITAL IGNITION CONTROLLER	11
INSTALLATION.....	12
MOUNTING.....	12
EXPLODED VIEW.....	13
MOUNTING EXAMPLES	14
WIRING	16
ANALOG OUTPUTS	18
SCHEMATIC.....	19
PIN OUT	20
SETUP AND CONFIGURING	21
REMOTE DISPLAY SCREENS	21
SET OUTPUTS	22
SETTINGS	23
GYRO SETTINGS	25
TIME SLIP SETTINGS.....	26
VPS WHEELIE CONTROL	28
TRACTION CONTROL	31
UTILITIES.....	36
VPS CONNECTED TO A PROFILER	39
PROFILER WHEELIE CONTROL (Profiler Only)	40
PROFILER CHANNELS (Profiler Only).....	43
FIRMWARE UPDATING.....	44
APPENDIX A	45

DISCLAIMER46
NOTES48
NOTES49
CONTACT INFORMATION50

THIS PAGE LEFT BLANK

INTRODUCTION

The Vehicle Position Sensor is designed to give the racer a new level of data that has been previously unavailable. Combining that data from multiple types of sensors including accelerometers, gyros, and magnetometers the VPS can quickly and accurately measure tiny changes in acceleration or rotation in all 6 axes, Gx, Gy, Gz, Pitch, Roll and Yaw.

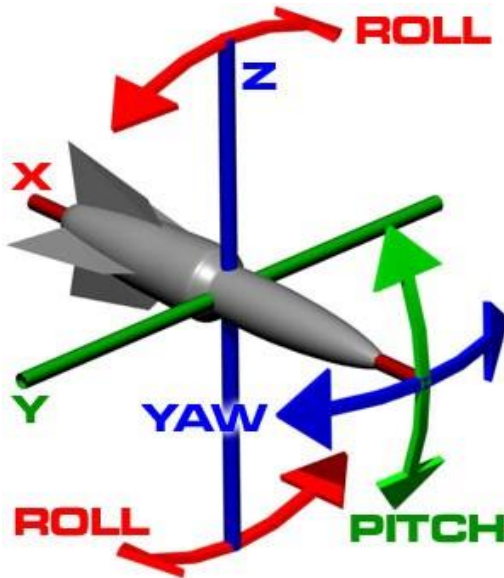

This data can be used to help determine the performance of the vehicle as well as control aspects of its behavior, such as excessive Pitch (wheelie). The VPS transmits its data through 5 analog outputs, serial (Profiler units only), and CAN-BUS.

The VPS provides the data in two formats. Direct data from the various sensors and Fusion data. Direct data is what it says, the data is sent directly from the internal sensors for that particular axis, i.e. Acceleration X, Y, Z or rotation rates from the Gyros. The Direct data is presented raw with no filtering for the utmost detail.

Fusion is an aggregate of multiple sensors “fused” together to provide the most well-rounded data. This type of data is commonly used in IMU’s which you may find on the internet or used in toys such as drones and hover boards.

Fusion data however, is reliable only when all of the sensors are functioning as expected. In the harsh environment of a race car, this is often not possible due to the extreme vibrations and electromagnetic fields generated by the ignition systems and other electrical systems found in a race car.

Therefore, Fusion data is only used for static setup and calibration.

DO NOT USE FUSION DATA WHEN CAR IS RUNNING OR ON THE TRACK!!!!!!

The VPS is oil filled and temperature controlled to enhance the quality of the data. It is normal for the VPS to be warm when running, approx. 100F.

REMOTE DISPLAY

The VPS can use a Remote Display (purchased separately) for the user to interface with the unit for setup and configuration.

If the VPS is connected to a Profiler (not PFEFI), which has a built-in color touch screen, then the Remote Display is not required. The Profiler screen is used to interface with the VPS. The Remote display can be used with many other Davis products such as the Profiler, PFEFI, Smart Relay, Digital Ignition Controller, and the TC3 series.



VIRTUAL TIME SLIP

The data is so accurate that the VPS can provide a Virtual Time Slip (VTS) that can be used to monitor vehicle performance even when no time slip is provided.

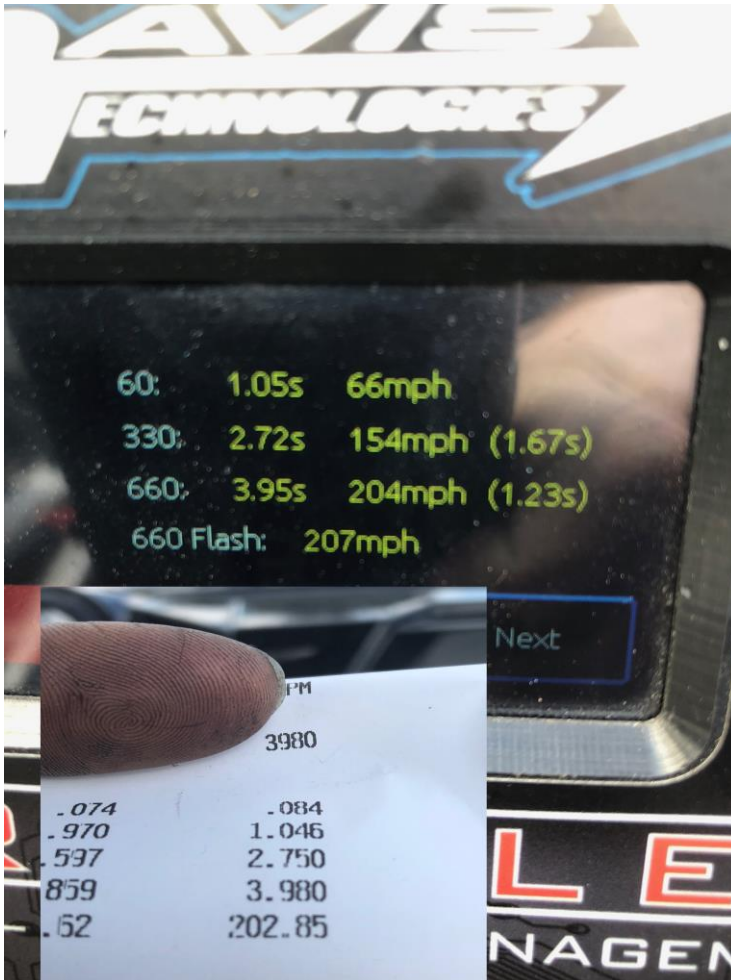

OPTIONAL CONTROL STRATEGIES

You can add other Davis Technologies systems as options to the VPS, such as Wheelie Control and Traction Control to make for a very powerful unit. Even a car with older ignition technology can use a VPS to add Wheelie control and Traction Control. Some systems may require the addition of a Digital Ignition Controller.

WHEELIE CONTROL (add-on purchased separately)

The VPS can have a Wheelie Control installed to control excessive pitch. The user can also take the analog data into another system, such as an EFI and create their own strategy of reactions to excessive movement. This could be configured to react to excessive reading in any axis.

Depending on the system receiving the VPS data, the user could build strategies to react to the vehicles movement that may be undesirable. Think about Roll Control, Pitch Control, Yaw Control, Side Impact, etc.

Example Screen of VPS Wheelie Control (optional)

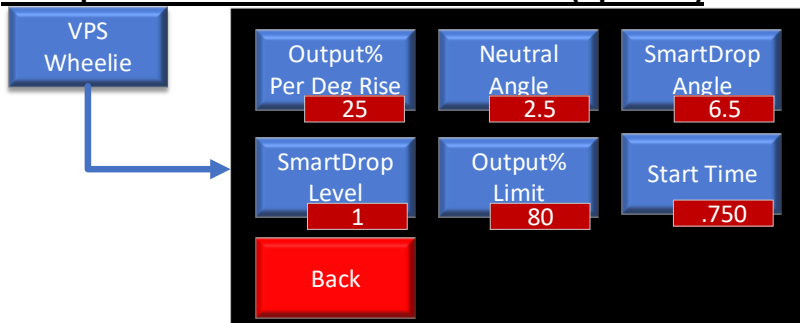

TRACTION CONTROL (add-on purchased separately)

The VPS can optionally have a **Traction Control Strategy** installed to control excessive tire slip. The traction control can be in the form of either Davis Technologies' Non-Self Learning Traction Control or Self Learning Traction Control.

Example Screen of VPS Traction Control (optional)

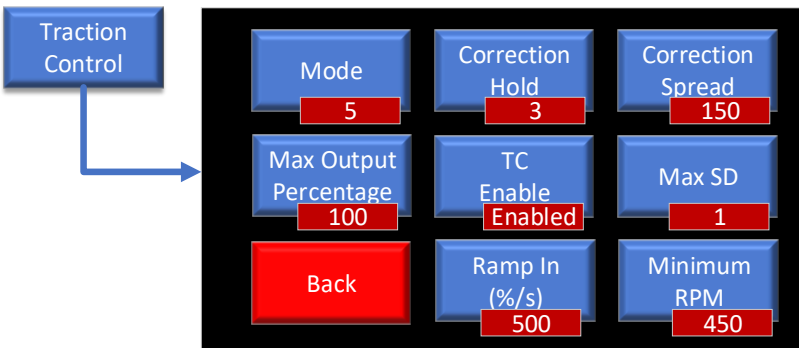

The optional control strategies can be installed at anytime online using the onboard USB port, after a license is purchased from Davis Technologies. Contact Davis Technologies for more information on how to add the optional features.

DIGITAL IGNITION CONTROLLER

The VPS can also be used in conjunction with the Digital Ignition Controller from Davis Technologies to control the ignition of most any type of stand-alone ignition system. The user does not need a Profiler or EFI to use the VPS for Wheelie Control or Traction Control. This can be useful for updating an older technology race car with some of today's latest technology. The Digital Ignition Controller (DIC) can be used to control timing, rev limiters as well as SmartDrop® cylinder dropping.

The outputs from the VPS can be used to signal the DIC to control the ignition to implement Wheelie Control or Traction Control.



INSTALLATION

MOUNTING

The VPS comes with mounts to clamp to a standard 1-5/8" roll bar. The VPS does need to be mounted securely in the vehicle in a level position and parallel with the centerline of the car front to rear. The VPS can be mounted with the sticker facing up or down and the connector pointing forward or backward.

The bar clamps are provided for ease of installation but are not required if you prefer to mount in another manner. However, the 3 studded rubber mounts **MUST** be used. Use care when installing the rubber mounts, and **DO NOT OVERTIGHTEN** the mount or the 8/32" nuts. The mounts are specially designed for the VPS and will tear apart if overtightened. **Do NOT use any other type of mount- the VPS will only function properly with the mounts supplied!**

If a mount is damaged during installation or during use, Super Glue or Black Weather Strip adhesive provides an excellent repair. **IT IS HIGHLY RECOMMENDED TO KEEP SOME SUPER GLUE IN THE TRAILER SHOULD THE NEED FOR REPAIR ARISE.** One spare mount is included in the kit.

EXPLODED VIEW



MOUNTING EXAMPLES



Supplied Rubber mounts **MUST** be used.



Here are a few Mounted examples.



WIRING

As with all electronic devices, proper wiring techniques and methods will result in the best performance. Proper terminations, wire routing and overall quality of work are required for proper operation. You may want to refer to this document for some tips on basic wiring principles- https://moretraction.com/wp-content/uploads/2019/01/Wiring-How-To_Web.pdf.

The VPS requires power and ground from the car. We recommend powering the VPS with the ignition switch providing 12-18 volt. As always, a good ground must be provided.

A trans brake signal is required to zero the VPS just before launch as well as provide a reset for the Virtual Time Sip. The TB signal can be a positive or negative trigger.

An arming switch can also be installed to enable/disable the Wheelie Control and Traction Control outputs if those features are installed.

If the VPS is installed in conjunction with a Profiler (not PFEFI), then you only need to connect the VPS to Power and Ground and the Serial RX / Serial TX wires. In this case, there is no need to connect a Trans Brake signal or Arming switch, as this info will be sent to VPS from the Profiler.

CAN is used to connect to other Davis products such as the Profiler EFI Module (PFEFI), TC3 Series, or The Digital Inline Controller (DIC). CAN may also be used with other manufactures equipment as

those protocols are published and integrated.

The harness is populated with the wires for the most common installation. All other wires are included and can be installed by the user, along with spare pins.

A special tool is recommended for pin removal (Molex #63824-4600 CT15), however a .025" round pin may work.



If pins are removed, the lock tab will need to be bent back into place if reinstalled in the connector.

Connector is a Molex Nano-Fit, using pin number #1053002200



Extraction Tool and replacement pins can be obtained from Digi-Key.

Extraction Tool- [WM11927-ND](#)
Pins- [WM14957CT-ND](#)

ANALOG OUTPUTS

The 5 analog outputs (0-5v) can be wired to an external data system or EFI to record or use the data however the user sees fit. Each output can be configured to send out any of the available parameters, such as Pitch, Roll, Yaw or any axis of Acceleration data.

Scaling:

Accel- 0-5v = -5g / +5g (2.5v = 0g)

Rotation- 0-5v = -12 deg / +12 deg (2.5v = 0 deg)

Example Analog Output Setup Screen

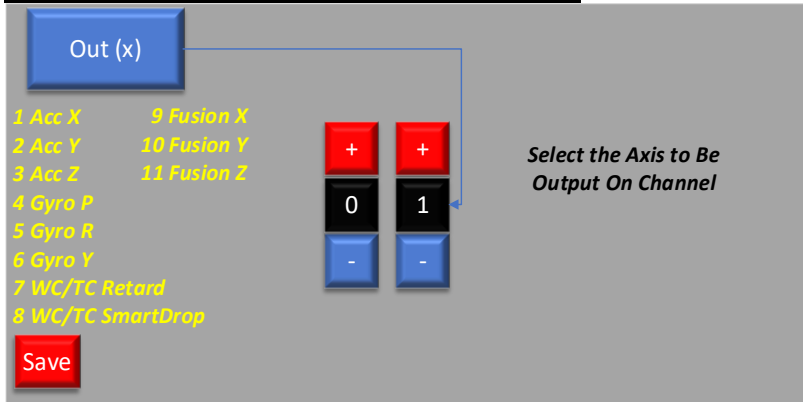

Acc X = Longitudinal Accel

Acc Y = Lateral Accel

Acc Z = Vertical Accel

Gyro P = Pitch

Gyro R = Roll

Gyro Y = Yaw

WC/TC Retard = Wheelie/TC Retard

WC/TC SmartDrop = Wheelie/TC SmartDrop

Fusion X = Fusion Pitch

Fusion Y = Fusion Roll

Fusion Z = Fusion Yaw

Fusion is only to be used when vehicle not running

SCHEMATIC

VPS Vehicle Position Sensor

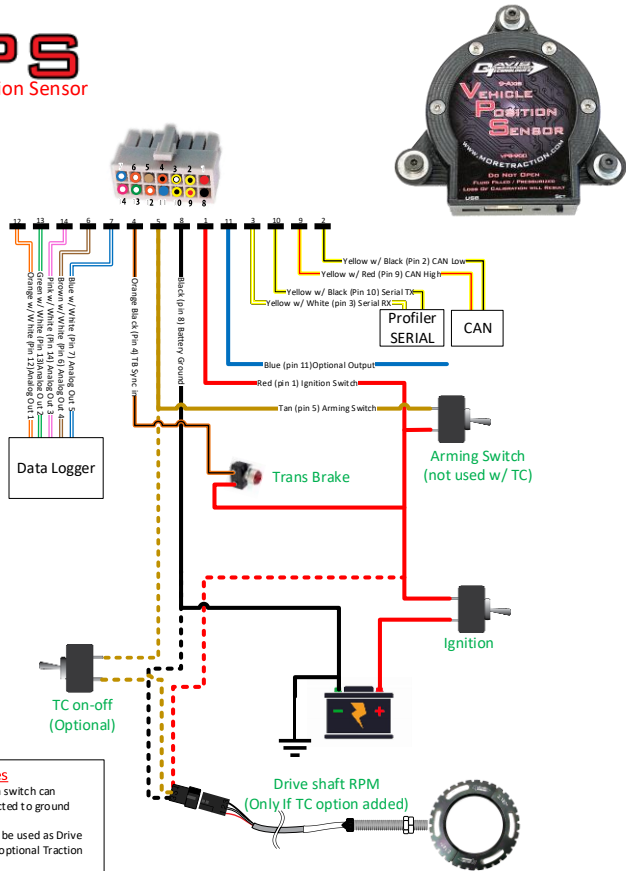

Notes

- Trans Brake and arm switch can optionally be connected to ground source
- Tan Wire (Pin 5) can be used as Drive Shaft Speed input if optional Traction Control is installed.
- Analog Outputs are 0-5 volt
- Acceleration Axes are scaled -5g/+5g
- Angles are scaled -12 deg/+12 deg
- Profiler Serial only used with Profiler, not Profiler EFI Module
- CAN is for use with compatible systems only

3/16/19

Other products and comp anes referred to herein are trademarks or registered trademarks of their respective companies or mark holders. Any components shown are for illustration or instructional purposes only.

DAVIS
GOAT TRACKING
TECHNOLOGIES
WWW.MORETRACTION.COM

PIN OUT

Pin	Color	Function
1	Red	Battery Positive - Ignition Switch
2*	Yellow w/ Black Stripe	CAN Low
3* #	Yellow w/ White Stripe	Serial RX
4	Orange w/ Black Stripe	Trans Brake Sync In
5	Tan	Arming Switch / DSRPM Input
6*	Brown w/ White Stripe	Analog Out 4
7*	Blue w/ White Stripe	Analog Out 5
8	Black	Battery Ground
9*	Yellow w/ Red Stripe	CAN High
10* #	Yellow w/ Black Stripe	Serial TX
11	Blue	General Purpose Output (50mA Batt Voltage / Ground)
12	Orange w/ White Stripe	Analog Out 1
13	Green w/ White Stripe	Analog Out 2
14	Pink w/ White Stripe	Analog Out 3

* Included, but not installed in connector

For use with Profiler Only- Not Profiler EFI Module

WARNING- DO NOT INSTALL SERIAL RX/TX IF NOT CONNECTED!!

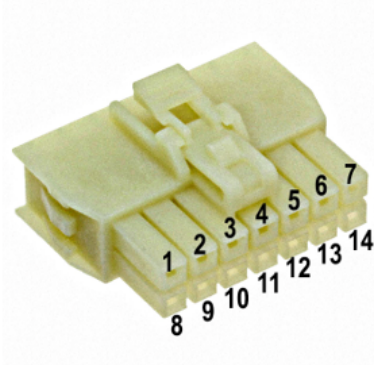

SETUP AND CONFIGURING

The VPS is configured using either a Remote Display or the screen built into a Profiler. Let's take a look at the display screens and how to configure the various settings and options.

**NOTE: ALL SETTINGS SHOWN ARE FOR EXAMPLE
ONLY-INDIVIDUAL SETTINGS WILL VARY**

REMOTE DISPLAY SCREENS

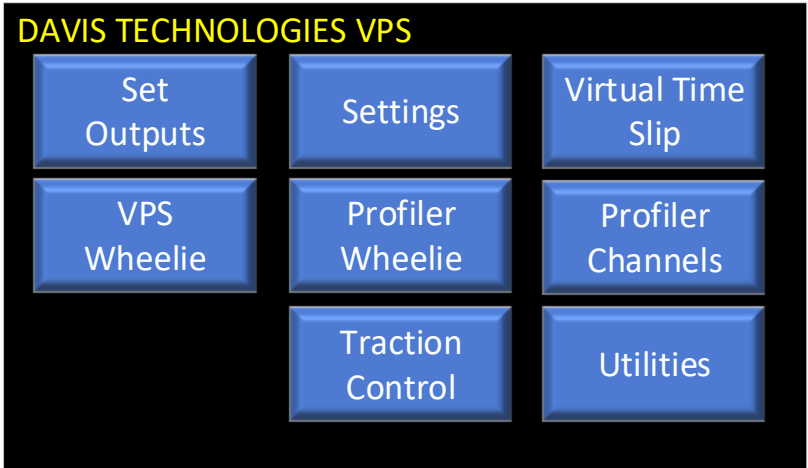

SET OUTPUTS

Use this screen to configure what parameter you want transmitted on any analog output. If connected to a compatible EFI system, you may need to set the output to the appropriate EFI mode to control the Retard and SmartDrop functions of the EFI.

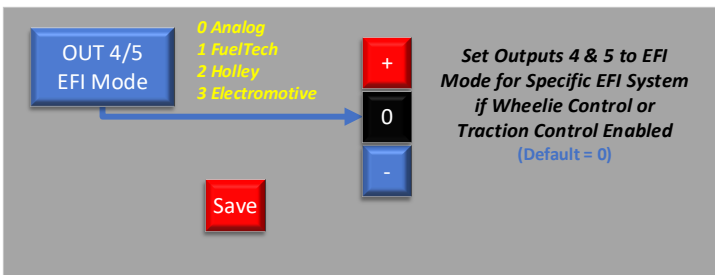
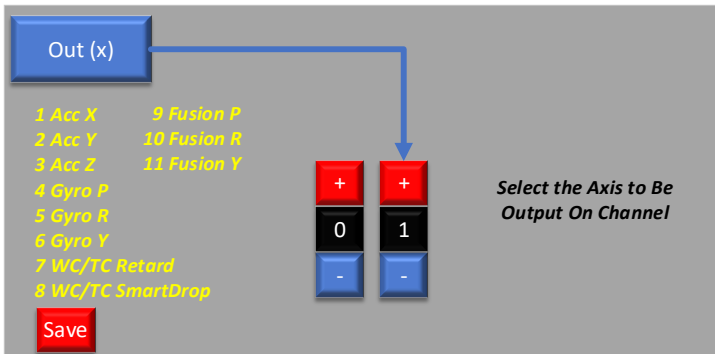

SETTINGS

Upon Installation various parameters need to be adjusted to match your cars configuration. RPM Pulses Per Rev only used if Traction Control Option is installed in VPS.

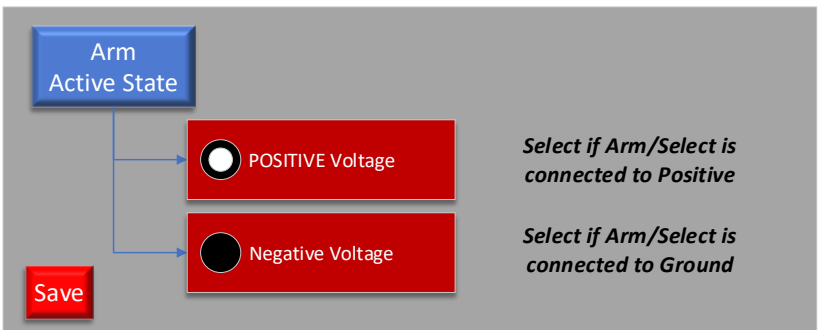
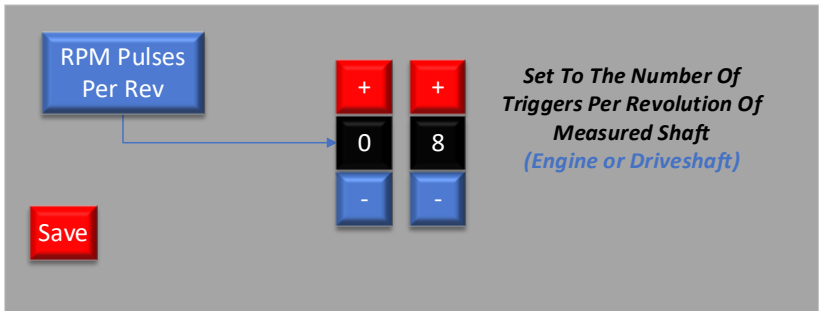
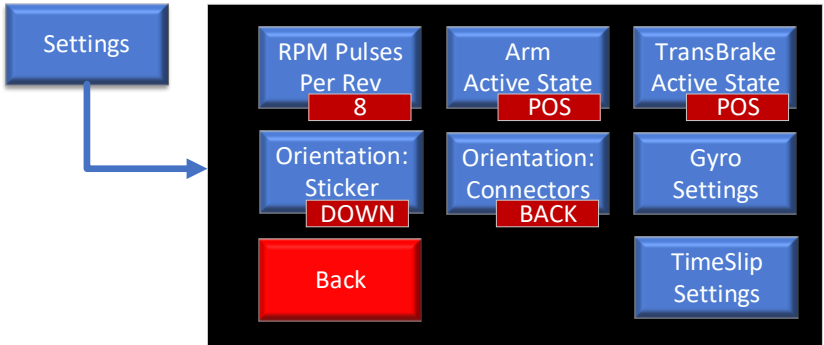

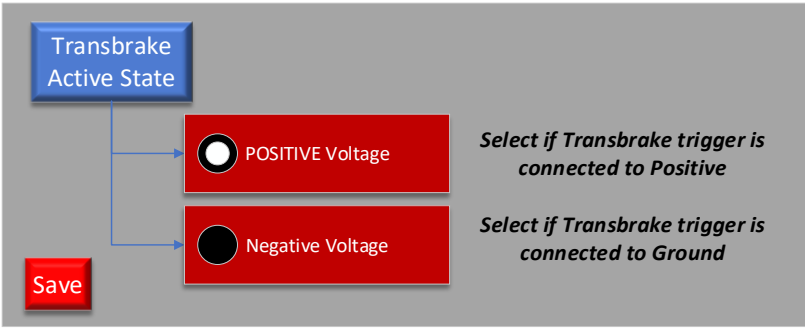

Be sure to set orientation setting to match mounted position of VPS.

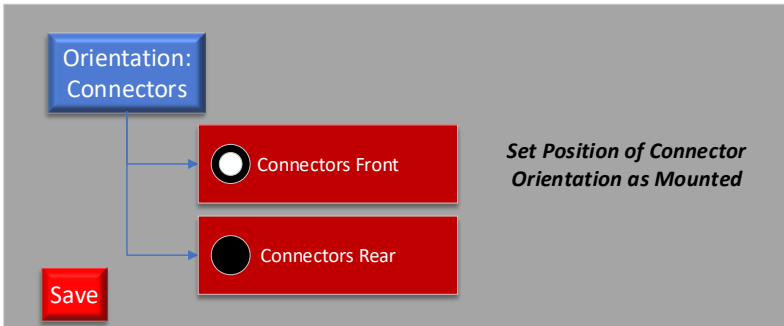
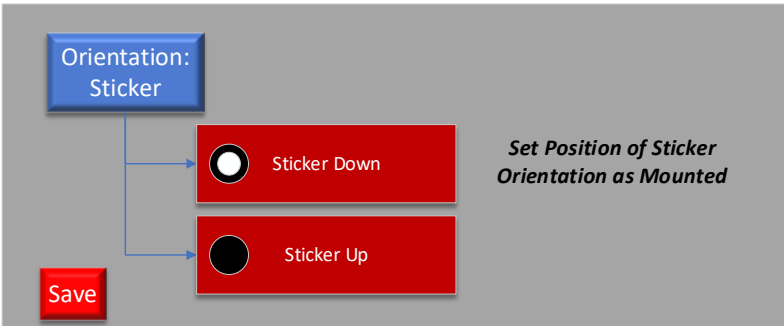

GYRO SETTINGS

Gyro Scaling can be set to best fit a particular need. Gyro Leak should only be adjusted with the guidance of Davis Technologies.

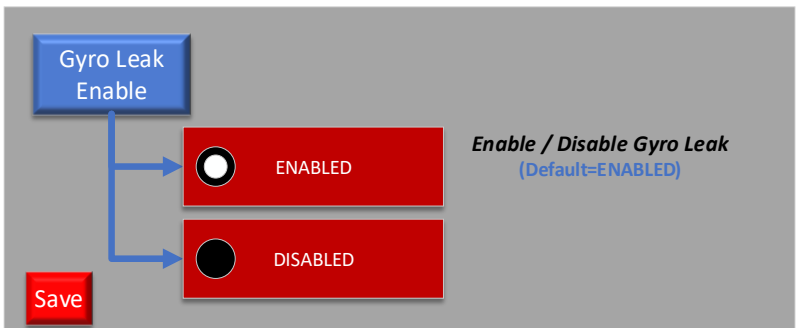
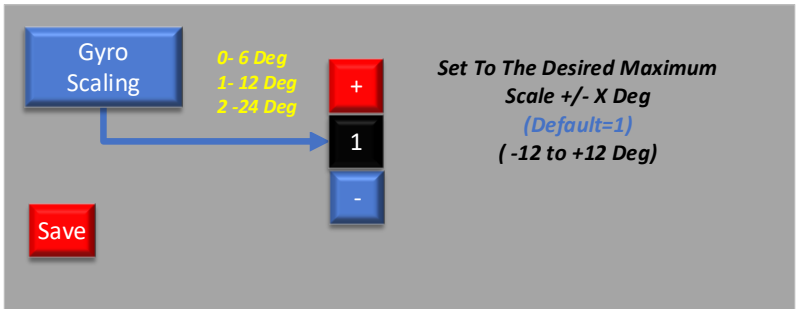
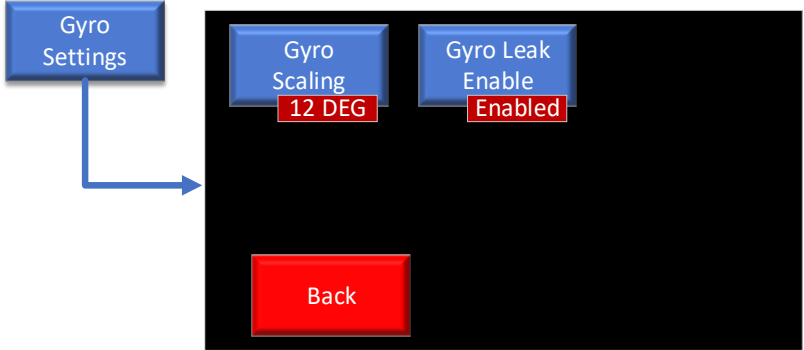

TIME SLIP SETTINGS

The Virtual Time Slip (VTS) is a very handy feature that can be used to monitor performance as changes are made.

Rollout greatly affects how the VTS compare to track slips, as the VPS begins calculating when the vehicle moves, and the track clocks start when the beams are triggered. If the VTS is **SLOWER** than the clocks, try **INCREASING** the Rollout setting. There will always be differences since it is nearly impossible to stage the car at exactly the same point on each pass. The data should be very consistent from one run to the next, so this can be very helpful when tuning without the aid of track clocks.

The Time Slip Distance calibrates the VPS for the distance it needs to measure. This parameter should be set to the current race distance. If this distance is not exceeded, then the VPS will continue to try to calculate the run and never finish, resulting in no slip. **The VPS stores 100 slips.**

Example Virtual Time Slip (VTS)

Virtual Time Slip

0	60:	0.95s	0mph
	330:	095s	0mph (0.00s)
	660:	0.95s	65535mph (0.00s)
	1320:	0.95s	65535mph (0.00s)

Max MPH at 660: 0mph
Max MPH at 1320: 0mph

Back Next Next

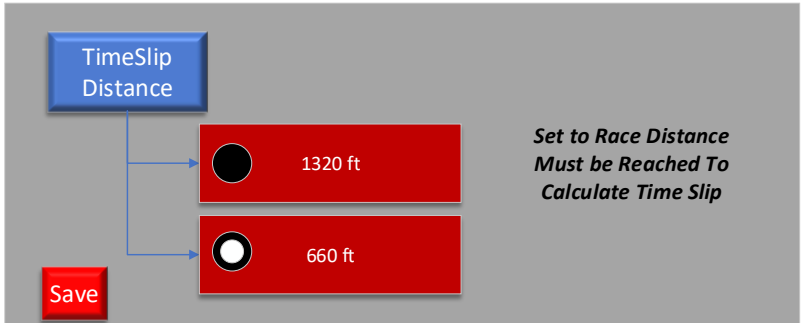
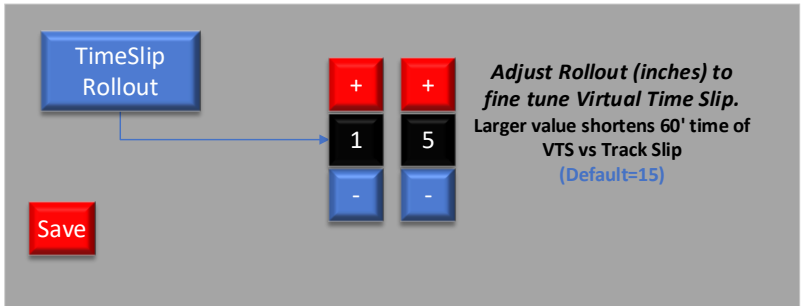
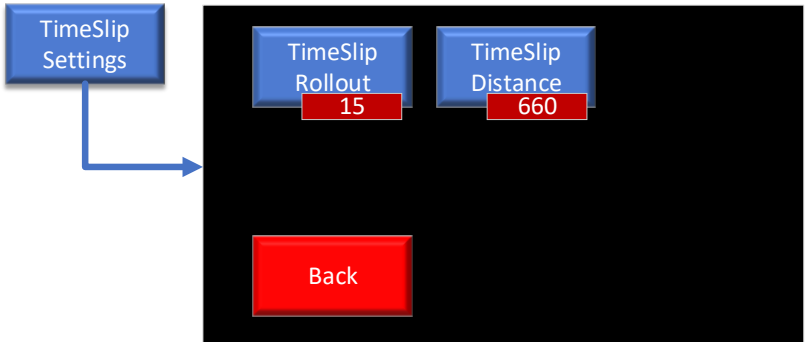

VPS WHEELIE CONTROL

If the optional Wheelie Control is installed, there are various parameter that need to be set for proper operation. The settings include the point at which the VPS will begin to send a signal to retard ignition timing (Neutral Angle- In Deg of Pitch) and the rate at which timing will be retarded (Output% Per Deg Rise)

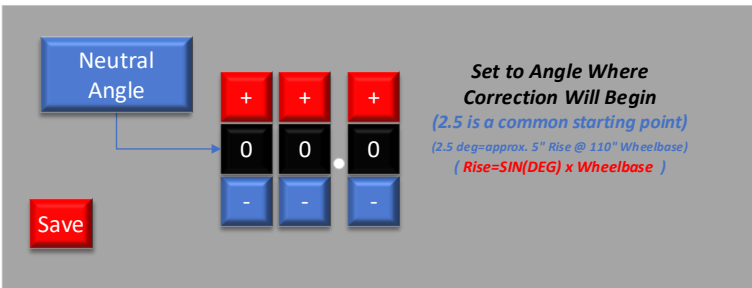
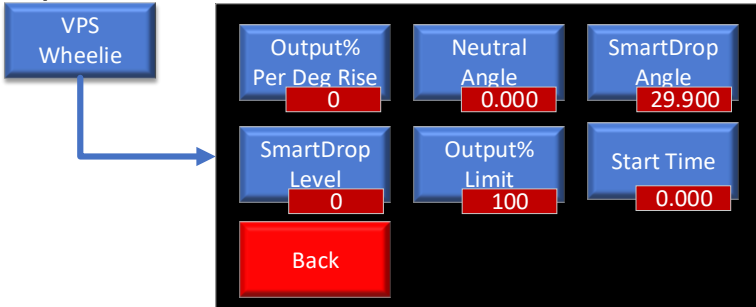

Output Limit is the maximum amount of timing that can be retarded and is also adjustable. This setting is useful to limit the total retard that the Wheelie Control can retard on different systems. For example, a 100% Retard correction on FuelTech is 35 deg of ignition retard, if you never want to retard more than 15 deg., then you would set the limit to 42%.

(15deg / 35deg=42%)

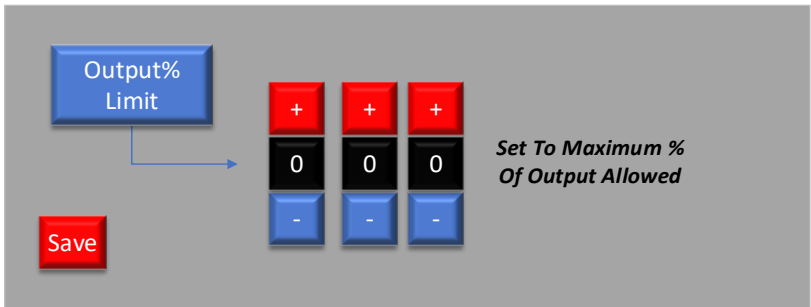

Start Time sets the time from Trans Brake release before the Wheelie Control is allowed to start controlling a wheelie. This can be useful on a car that does a harmless wheelie at the hit but pitching up later in the run is a problem and you need wheelie control down track.

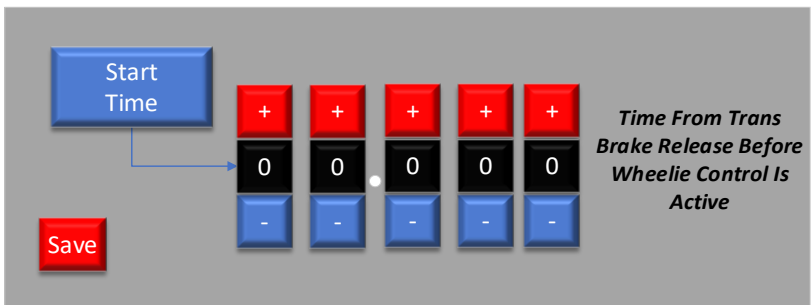

SmartDrop Angle is the angle at which the VPS will begin to send a signal to start dropping cylinders (SmartDrop) is also adjustable as well as the maximum level of SmartDrop, if any. This feature is only available when used with a compatible system, such as a Profiler, Davis Technologies Digital Ignition Controller, or some EFI systems (Holley, FuelTech).

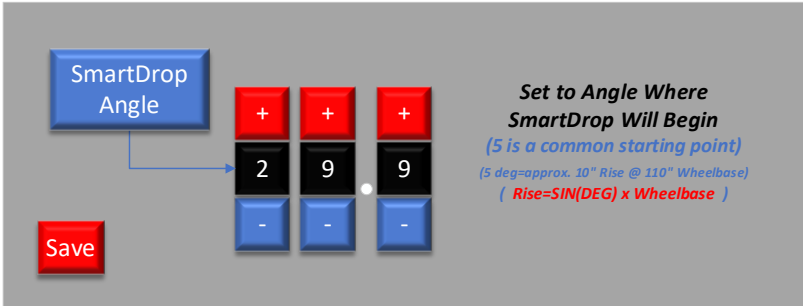

The screen shows a blue box labeled "SmartDrop Angle" with an arrow pointing to a numeric keypad. The keypad has three columns: the first column has a red "+" button above a black "2" button above a blue "-" button; the second column has a red "+" button above a black "9" button above a blue "-" button; the third column has a red "+" button above a black "9" button above a blue "-" button. A red "Save" button is on the left. To the right, text reads: "Set to Angle Where SmartDrop Will Begin (5 is a common starting point) (5 deg=approx. 10" Rise @ 110" Wheelbase) (Rise=SIN(DEG) x Wheelbase)".

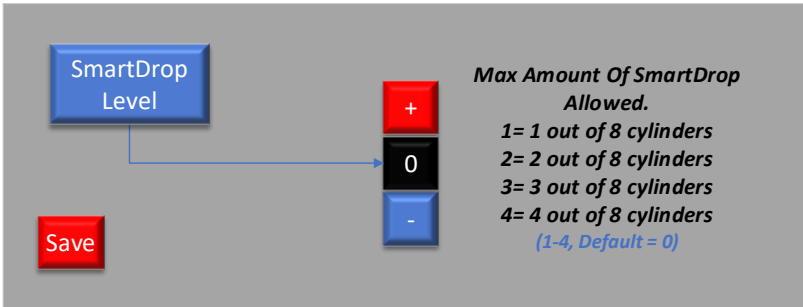

The screen shows a blue box labeled "SmartDrop Level" with an arrow pointing to a numeric keypad. The keypad has three buttons: a red "+" button, a black "0" button, and a blue "-" button. A red "Save" button is on the left. To the right, text reads: "Max Amount Of SmartDrop Allowed. 1= 1 out of 8 cylinders 2= 2 out of 8 cylinders 3= 3 out of 8 cylinders 4= 4 out of 8 cylinders (1-4, Default = 0)".

TRACTION CONTROL

The VPS can also have Davis Technologies Patented Traction Control installed as an option. If the Self Learning version of TC is installed, it can be disabled, and the TC can be used in Non-Self Learning Mode.

For maximum benefit, a few parameters need to be adjusted to suit your needs. These include things such as overall sensitivity (Mode), Total Retard (Max Output %), Max SmartDrop Allowed and Starting RPM.

Mode is overall sensitivity- the higher the value the more sensitive, a good starting point is 4-5.

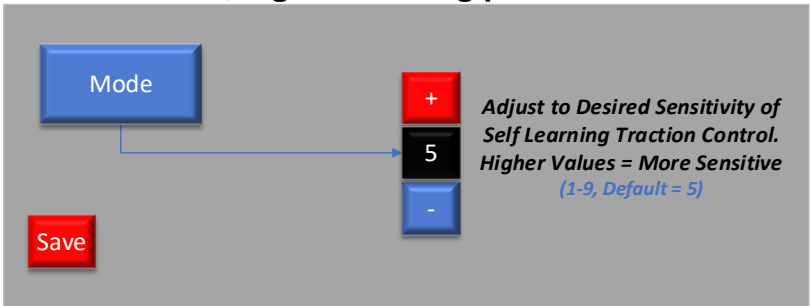

If desired, the Self Learn function can be disabled and TC functions in Non-Self Learning Mode.

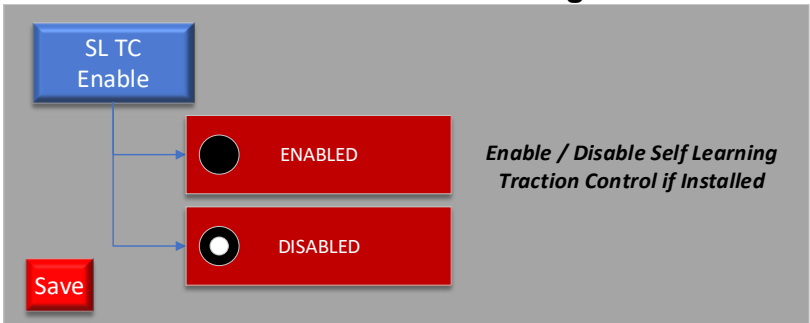

Correction Hold is used to force the TC system to hold the correction for X many revolutions of the measured shaft to give the vehicle some time to recover before the correction is removed.

Correction Hold

Save

+

3

-

Minimum Duration in Measured Shaft Revolutions that Correction is Held Once a Correction is Triggered (0-9, Default = 3)

Correction Spread controls the rate at which the system reaches the maximum correction allowed. Once a slip is detected, if the RPM reaches the top of the correction spread, then the correction will reach maximum. The correction is linear, so if the RPM spike only reaches 50% of the spread, then only 50% of the max correction will be allowed.

Correction Spread

Save

+

+

+

1

5

0

-

-

-

RPM Spread to Reach Maximum Correction After a Slip Is Detected (0-999, Default = 150)

If a correction is active, and the RPM spike exceeds the Correction Spread Value, then SmartDrop is initiated. If spread is set to 150, then at 151 RPM the first level of SmartDrop will be triggered. After that, if the RPM continues to spike, the SmartDrop will increase to the next level when the RPM increases another $\frac{1}{2}$ of the correction spread setting. So, if spread = 150, then SmartDrop will increase every 75 RPM. The SmartDrop will only increase in level to the Max SD Limit. SmartDrop 0=Retard Only

Example (correction spread 150 / SD increase every 75)-

Spike up to 150 RPM=Retard Only

Spike of 151-225 RPM=Full Retard and SD level 1

Spike of 226-300 RPM=Full Retard and SD level 2

Spike of 301-376 RPM=Full Retard and SD level 3

Spike of 377-xxx RPM=Full Retard and SD level 4

Max SD

Save

+

0

-

Max Amount Of SmartDrop Allowed. Begins Above Correction Spread

1= 1 out of 8 cylinders

2= 2 out of 8 cylinders

3= 3 out of 8 cylinders

4= 4 out of 8 cylinders

(1-4, Default = 0)

Maximum Output Percentage sets the maximum amount of retard that will be allowed by an external retarder, such as the Digital Ignition Controller or EFI system. For example, a 100% Retard correction on FuelTech is 35 deg of ignition retard, if you never want to retard more than 15 deg., then you would set the limit to 42%.
 (15deg / 35deg=42%)

Max Output Percentage

Save

+

+

+

1 0 0

- - -

Set to Max Amount of Output % When at Full Correction
 (20%=1/5th total correction maximum)

Ramp In is the rate at which timing retard is restored after a correction has ended. Ramp in is calibrated in % per sec. 100% restore rate will take 1 sec to restore the amount retarded, 1000% will take 10th of a second to restore the amount retarded.

Ramp In (%/s)

Save

+

+

+

+

+

0 1 0 0 0

- - - - -

Speed At Which Correction Is Ramped Back In After Correction Ends.
 (100%=Correction Restored Over 1 Second,
 1000%= Correction Restored Over 1/10th of a Second)
 (Default = 1000)

Minimum RPM sets the RPM of the measured shaft below which the TC is not able to make a correction. This allows some cars to “Get Up On The Tire” before any corrections are allowed.

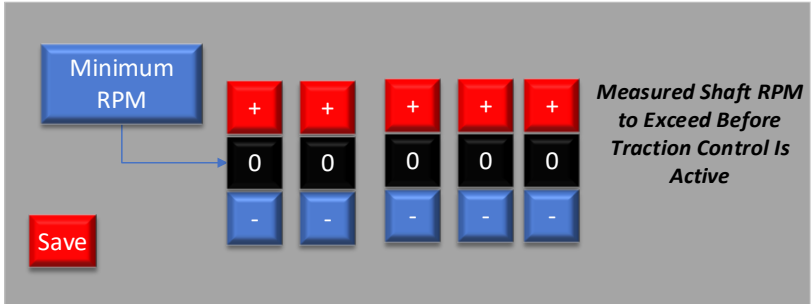

UTILITIES

The utilities menu has many useful features that can be used during initial setup, configuring features such as Wheelie Control, as well as information about current firmware or to execute a Factory Reset.

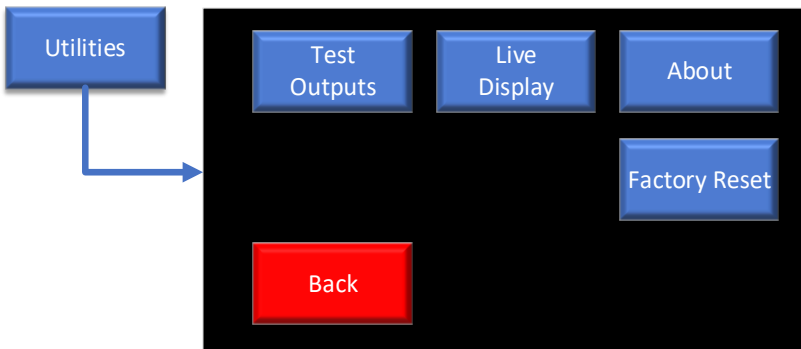

Test Outputs is useful when connecting to an external system to confirm that the devices are functioning as expected. Press any button to execute an output. The output will ramp up to 5v, then ramp down to 0v, and return to 2.5v idle until the Test screen is exited.

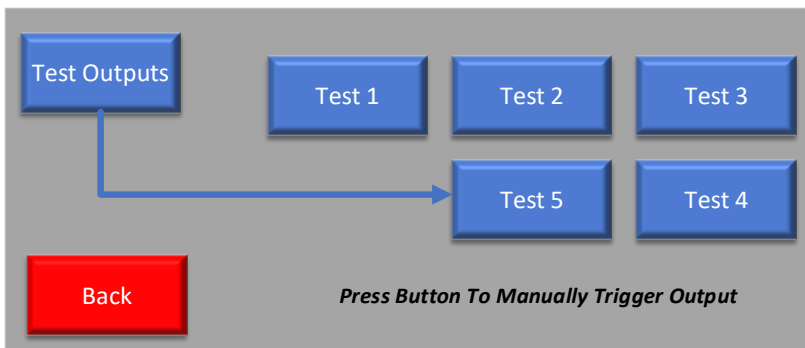

Live Display gives a real time display of all channels on the top half of the screen (in red) and the programmed outputs on the lower half (in blue). The red tags will display angles in fusion mode and are very useful when setting up features such as wheelie control. If the blue meters are set to display a non-fusion angle, then you will notice if you move to an angle and hold, the meter will “drift” back to neutral. If you move to an angle and constantly make tiny movements (vibrations, as if the car was running) at that angle, the meter will not drift.

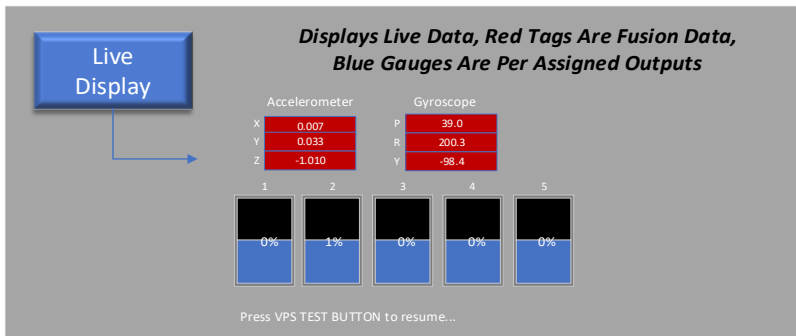

The **About** Screen provides info about current firmware and status.

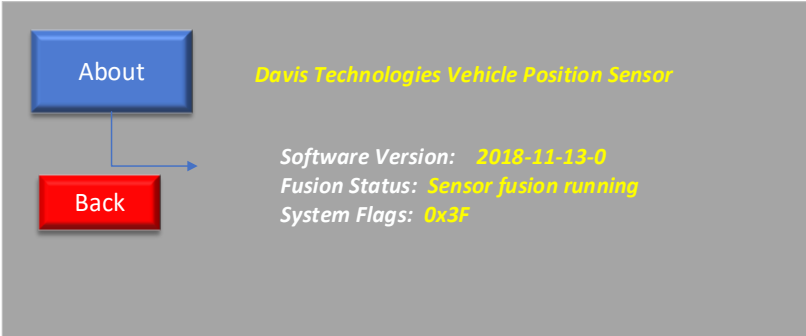

Factory Reset can be used to restore all settings to factory settings.

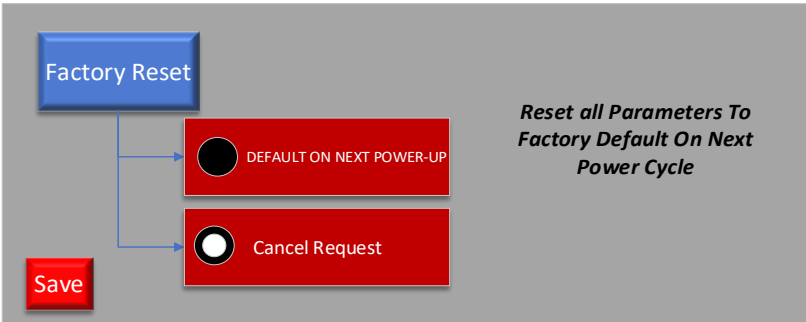

VPS CONNECTED TO A PROFILER

When the VPS is connected to a Profiler, the touch screen built into the Profiler serves as the interface to the VPS.

Profiler Wheelie Control varies slightly from VPS Wheelie Control and has slightly different features.

The Profiler is also able to record and display any 2 of the outputs of the VPS. This is very useful for recording Acceleration (Gx) data on the Profiler to aid in tuning the DSRPM plot. If wheelie control is being used, it may also be beneficial to record Pitch (Gyro P) on the Profiler.

The data is presented on the DSRPM graph of the Profiler software. Acceleration data is zeroed along the **4000 RPM line, and every 1000 RPM is 1 G**. We are mostly interested in the G trend, up/down to analyze and tune the DSRPM plot. We need to see when the G dropped, to determine tire slip.

Angle data is presented on the DSRPM graph of the Profiler software also. Angle data is zeroed along the **3000 RPM line, and every 250 RPM is 1 Deg**.

NOTE: To use the Profiler Wheelie Control, Profiler Channel 1 MU-ST be set to Pitch (parameter 4)

PROFILER WHEELIE CONTROL (Profiler Only)

If the VPS is connected to a Profiler (not PFEFI) and the optional Wheelie Control is installed, there are various parameters that need to be set for proper operation. The settings include the point at which the VPS will begin to send a signal to retard ignition timing (Neutral Angle- In Deg of Pitch) and the rate at which timing will be retarded (Deg per Rise)

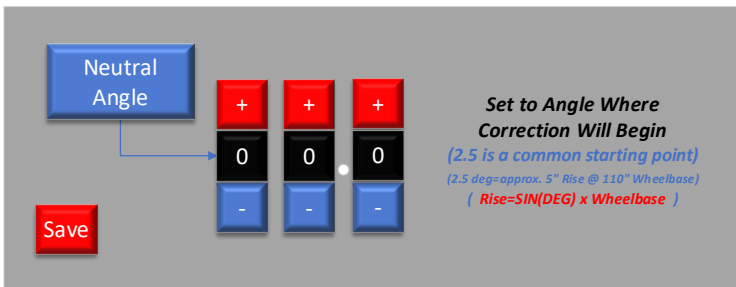
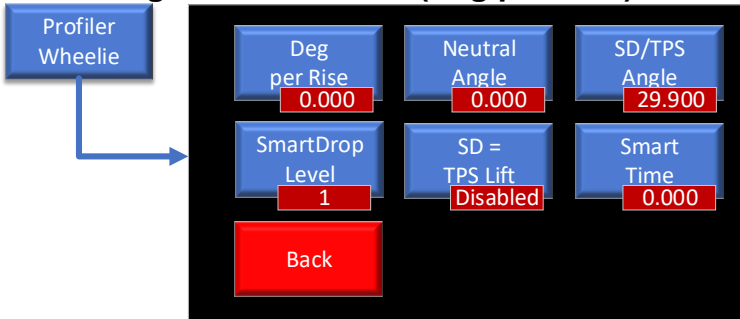

The angle at which the VPS will begin to send a signal to start dropping cylinders (SmartDrop) is also adjustable as well as the maximum level of SmartDrop, if any.

SD/TPS Angel

Save

Set to Angle Where SmartDrop/TPS Lift Signal Will Begin
(5 is a common starting point)
(5 deg=approx. 10" Rise @ 110" Wheelbase)
(Rise= $\text{SIN}(\text{DEG}) \times \text{Wheelbase}$)

SmartDrop Level

Save

Max Amount Of SmartDrop Allowed.
 1= 1 out of 8 cylinders
 2= 2 out of 8 cylinders
 3= 3 out of 8 cylinders
 4= 4 out of 8 cylinders
(1-4, Default = 0)

Another unique feature of the Profiler Wheelie Control is the ability to trigger a pseudo TPS lift within the Profiler Events to cause one of the Outputs to react as if the driver pedaled, instead of dropping cylinders. This could be used to control a convertor dump, nitrous kit, shift, etc.

SD = TPS Lift

Save

ENABLED

DISABLED

Enable to Send TPS Lift Signal to Events Instead of Dropping Cylinders When SmartDrop Level Exceeded
(Default = DISABLED)

Start Time sets the time from Trans Brake release before the Wheelie Control is allowed to start controlling a wheelie. This can be useful on a car the does a harmless wheelie at the hit, but pitching up later in the run is a problem and you need wheelie control down track.

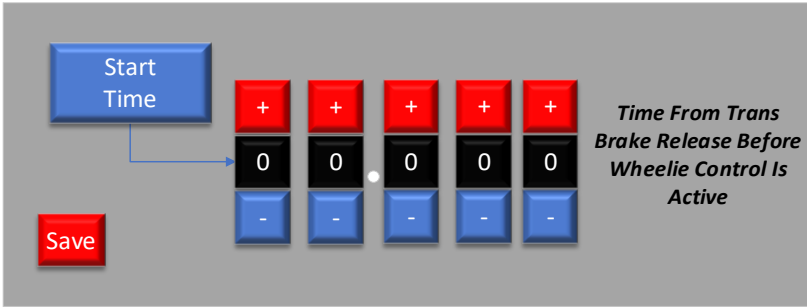

Note: To use the Profiler Wheelie Control, you must set Profiler Channel-1 to Parameter 4 (Pitch) to activate. See Profiler Channels in the next section for details.

PROFILER CHANNELS (Profiler Only)

When the VPS is connected to a Profiler (not PFEFI), you can also record any 2 channels on the Profiler and view them in the software. This is extremely useful for evaluating the acceleration performance of the car during the run. Determining when Longitudinal G is rising or falling is key to tuning the Profile to the proper levels.

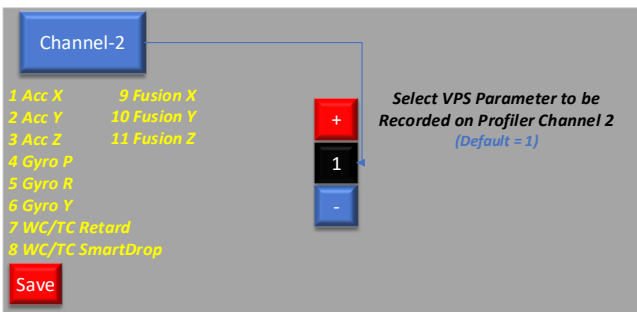
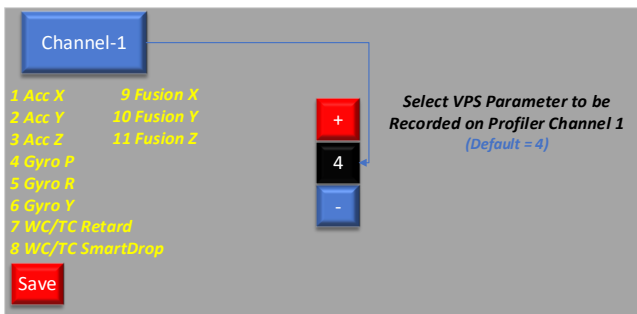
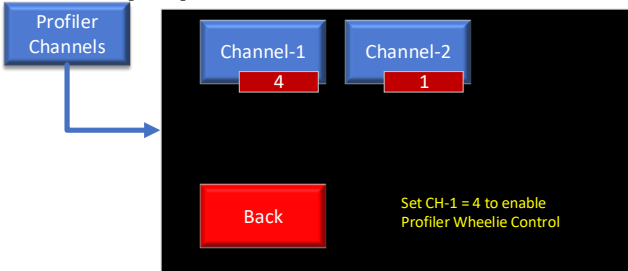

FIRMWARE UPDATING

Davis Technologies may release firmware updates or upgrades periodically to ensure the best possible functionality of the system. These are typically installed using the USB connector and the supplied USB cable. Instructions for this procedure will be included in the firmware update file located on the web site.

Users should log onto <https://moretraction.com/support/> occasionally to check for updates. And make sure their device has the most recent firmware.

APPENDIX A

The VPS data can be recorded on a RacePak via a V-Net module.

RacePak part # 230-VM-5VDIFF can be used to record 1 channel. (approx.. \$160)

RacePak part # 230-VM-USM can be used to record 4 channels. (approx.. \$300)

RacePak® V-Net Pin Out

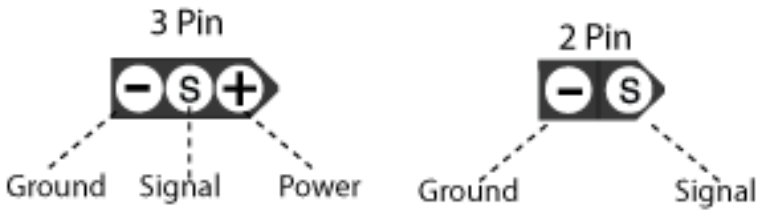

DISCLAIMER

FOR RACING PURPOSES and OFF ROAD USE ONLY!

Vehicle racing is an inherently dangerous sport with significant risk of personal injury or even death. When a user participates in vehicle racing and/or track events, he accepts the risk inherent therein. Davis Technologies LLC ("DAVIS"), its employees, and affiliates makes no warranty that the use of its products or parts guarantees personal safety or freedom from physical injury or operates as a life saving device.

Davis Technologies LLC's ("DAVIS") PRODUCTS AND PARTS ARE SOLD "AS IS" WITHOUT ANY WARRANTY WHATSOEVER. EXPRESS WARRANTIES, IMPLIED WARRANTIES, WARRANTIES OF MERCHANTABILITY AND WARRANTIES OF FITNESS FOR A PARTICULAR PURPOSE ARE EXCLUDED. THE ENTIRE RISK OF QUALITY AND PERFORMANCE OF SUCH PRODUCTS AND PARTS IS WITH THE BUYER, USER, SUBSEQUENT USER, OR AGENT THEREOF (HEREIN "USER"). SHOULD SUCH PRODUCTS OR PARTS PROVE DEFECTIVE FOLLOWING THEIR PURCHASE, THE BUYER AND NOT THE MANUFACTURER(S), DISTRIBUTOR(S), OR RETAILER(S), ASSUME THE ENTIRE COST OF ALL NECESSARY SERVICES OR REPAIR AS RESULT OF A PART(S) FAILING.

Davis Technologies LLC ("DAVIS") disclaims all liability for any special, direct, incidental or consequential damages, or any damages whatsoever, including, without limitation, the loss of life or limb, or damages due to bodily or personal injury, which may arise or result from the sale, installation, or use of any of its products and parts.

It is the user's responsibility to inspect and verify the dimensions, specifications, and performance of all products and parts as being appropriate for the use to which the user will put them prior to any actual installation and/or use of said products and parts.

Davis Technologies LLC's ("DAVIS") products and parts are to be inspected by the user before each use for evidence of damage, defect or wear. Any deviation by the user from the manufacturer's specifications concerning use, maintenance, repair, alterations and modifications constitutes willful negligence.

The installation of Davis Technologies LLC's ("DAVIS") products or parts may adversely affect other vehicle components, safety equipment or manufactured goods (collectively "goods"). Davis Technologies LLC ("DAVIS") assumes no responsibility for any damage to other goods, or bodily injury that may arise due to failure of other goods, due to installation and/or use, either proper or improper, of its products or parts.

The liability of Davis Technologies LLC ("DAVIS") is limited to the replacement of defective products or parts found under examination by manufacturer to be defective in material or workmanship within 60 days after purchase, and which has not been caused by an accident, improper use, alteration, tampering, excessive use, misuse,

modification or abuse. The damage of the user shall be deemed liquidated in the costs of replacement of the product or part.

Davis Technologies LLC's ("DAVIS") assumes no responsibility for errors, omissions, diagrams, pictures, illustrations or text in these instructions or the documents contained herewith.

By purchasing or using this product, the user agrees that if any provision of this Disclaimer is held to be illegal, invalid or unenforceable under present or future law, such provision shall be fully severed from the Disclaimer and this Disclaimer shall be construed and enforced as if such illegal, invalid or unenforceable provision never comprised a part hereof, and the remaining provisions hereof shall remain in full force and effect and shall not be affected by the illegal, invalid or unenforceable provision, there shall be added automatically as part of this Disclaimer a provision as similar in its terms to such illegal, invalid or unenforceable provision as may be possible and be legal, valid and enforceable.

NOTES

NOTES

CONTACT INFORMATION

Technical support and sales may be reached at:

DAVIS TECHNOLOGIES, LLC.

PO Box 8250

Asheville, NC. 28814

(828) 645-1505

(828) 645-1525 fax

email: support@moretraction.com

web: www.MORETRACTION.com





WWW.MORETRACTION.COM